

DEUTSCH	3
ENGLISCH	14
FRANÇAIS	25
ITALIANO	36

BETRIEBSANLEITUNG UND SICHERHEITSVORSCHRIFTEN
OPERATING AND SAFETY INSTRUCTIONS
MODE D'EMPLOI ET DE SÉCURITÉ
ISTRUZIONI PER L'USO E DI SICUREZZA

OR-T 83

Ab Serie-Nr. 13'412

From serie no 13'412

A partir du no de série 13'412

A partire dal no di serie 13'412

Handgerät zum Umreifen mit Kunststoffband

Hand tool for plastic strapping

Appareil pour cerclage par bande plastique

Apparecchio per reggiare con reggetta di plastica



Vor dem Gebrauch des Gerätes die Betriebsanleitung aufmerksam lesen.

Before using the tool, read the operating instructions carefully.

Avant l'utilisation de l'appareil, consultez soigneusement le mode d'emploi.

Prima d'utilizzare l'apparecchio, leggere attentamente le istruzioni per l'uso.



TABLE OF CONTENTS

	Page
1 Technical data	14
2 General information	15
2.1 Information on environmental protection	15
3 Safety instructions	16
3.1 Safety instructions for battery charger and battery	16
4 Description	17
4.1 Design	17
4.2 Battery charger indicators	17
5 Initial operation	18
5.1 Battery charger	18
5.2 First battery charge	18
5.3 Charging the battery	18
6 Operating instructions	19
6.1 Operating the tool	19
7 Preventive and corrective maintenance	22
7.1 Changing the battery	22
7.2 Adjusting welding time	22
7.3 Adjusting strap tension	23
7.4 Adjusting strap width	23
7.5 Cleaning the tool	24
7.6 Changing the tension wheel	24
7.7 Changing the tension shoe	24
8 Recommended spare parts	47
8.1 Parts list	47
Explosion drawing	53

1

TECHNICAL DATA

Weight	4 kg (8.8 lbs.)
Dimensions	Length 400 mm (15.75") Width 130 mm (5") Height 200 mm (7.90")
Strap tension	With friction clutch fully variable up to 2000 N (440 lbs.) depending on strap quality
Sealing	Friction welded
Voltage	Battery charger 230 V (115 V) Battery 12 V
Emission sound pressure levels, measurement type A (EN ISO 11202)	L_{pA} 83 dB (A)
Vibrations at handle (EN ISO 8662-1)	$a_{h,w}$ 7,3 ms ⁻²
PLASTIC STRAP	
Strap quality	Polypropylene (PP) Polyester (PET)
Strap width	9–10, 12–13, 15–16 or 19 mm ($\frac{3}{8}$ " , $\frac{1}{2}$ " , $\frac{5}{8}$ " or $\frac{3}{4}$ ")
Strap thickness	0.5–0.9 mm (.019"–.035")

DECLARATION OF AGREEMENT

We take sole responsibility for declaring that the tool OR-T 83, to which this declaration refers, is in full compliance with the current requirements of the guidelines laid down by the council on 22th June 1998 (98/37/EEC), "Machine Guidelines".

Furthermore, electrical installations are in accordance with the guideline laid down by the council on 3th May 1989 (89/336/EEC) „EMV Guidelines“.

According to norm:
EN ISO 12100-1, EN ISO 12100-2, EN 349,

EN 1050, EN 50082-2, IEC 61000-6-2, EN 55022, EN 50081-1

CH-8953 Dietikon, September 2001

Manager
Sales & Marketing:



R. Kieffer

Manager
Engineering:



M. Binder

2

GENERAL INFORMATION

These operating instructions are intended to simplify familiarisation with the strapping tool and its proper use for the intended purpose. The operating instructions contain important information concerning the safe, proper and efficient use of the strapping tool. Compliance with the instructions will help to avoid danger, reduce repairs and stoppages and increase the reliability and service life of the strapping tool.

The operating instructions must always be available at the place of operation of the strapping tool. They must be read and observed by all persons concerned with work on the strapping tool. This work specifically includes operation, refilling of operating material, fault elimination and maintenance.

In addition to the operating instructions and the regulations for accident prevention effective in the country of use and place of application, the recognised technical regulations for safety and proper operation must also be observed.



CAUTION!

Used where there is danger to life and health.



WARNING!

Used for danger which can cause material damage.

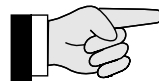

NOTE!

Used for general information and information which, if not followed can cause faults in the operating sequence.

2.1 INFORMATION ON ENVIRONMENTAL PROTECTION

This tool is manufactured without any physical or chemical substances which could be dangerous to health.

For disposal of all the parts, the governmental instructions must be observed. The electrical assemblies should be dismantled so that the mechanical, electro-mechanical and electronic components can be disposed of separately.

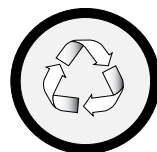

Dealers provide an environmentally-friendly battery disposal service

- Do not open the battery.
- Do not throw the used battery into household waste, fire or water.

Defective or used batteries undergo a complete recycling process.

3

SAFETY INSTRUCTIONS



Inform yourself!
Read the operating instructions carefully. Preventive and corrective maintenance on the tool may only be carried out by trained personnel.



Original ORGAPACK spare parts must be used exclusively!
Not using original spare parts will dissolve the warranty and the liability.



Protect yourself!
When operating the tool, wear eye, face and hand protection (cut-proof gloves).

Use for the intended purpose

This tool is designed for strapping packages, pallet loads and the like.

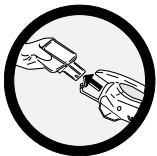

Power source!
Before starting preventive or corrective maintenance, remove battery from the tool.

The tool was designed and manufactured to provide safe handling during the strapping operation.

The tool is designed for use with plastic straps (polypropylene and polyester).



Warning:
Strap will snap forward!
When cutting the strap, hold the upper portion and stand safely away from the strap.
Caution:
The lower strap will snap forward.

Possible misuse

The use of steel straps is not possible.

3.1 SAFETY INSTRUCTIONS FOR BATTERY CHARGER AND BATTERY



Warning:
Strap could break!
Do not stand in line with the strap while it is tensioned. The strap could break!



Always inspect the electrical plug and cable before use. If damaged, they must be replaced by qualified personnel.



Caution:
Only strap packed goods!
Do not put hands or other parts of the body between the strap and the package during the strapping process.

- Do not charge other types of batteries (see chapter 5.1) and use original accessories only.
- Keep the battery charger slot free of foreign objects and protect against dirt.
- Protect the battery charger against humidity and use it in dry areas only.
- Do not open the battery. Protect the battery against impact, heat and fire. Risk of explosion!
- When the battery is outside the battery charger, cover its battery terminals to avoid short circuits with metal objects. Risk of fire and explosion!
- Keep battery dry and protected against frost. Do not store it at temperatures over 50°C or below 10°C.
- Damaged batteries should not be used longer.



Caution:
Danger of squeezing!
Do not put your fingers into the tension wheel area.



Do not use water!
Do not use water or steam to clean the tool.

4

DESCRIPTION

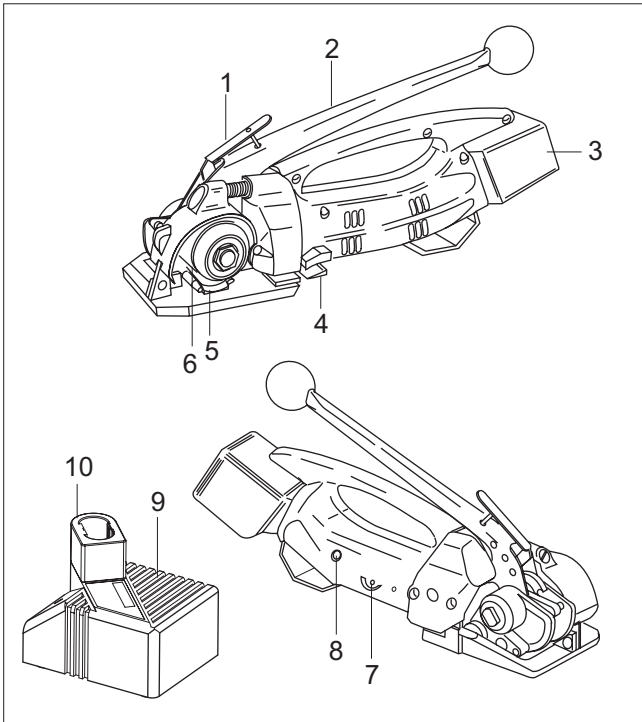

Fig. 1

4.1 DESIGN

- 1 Welding lever
- 2 Tension lever
- 3 Battery
- 4 Cutting device
- 5 Tension shoe
- 6 Tension wheel
- 7 Potentiometer „Welding time“
- 8 Indicator „Battery“
- 9 Battery charger
- 10 Adapter

4.2 BATTERY CHARGER INDICATORS

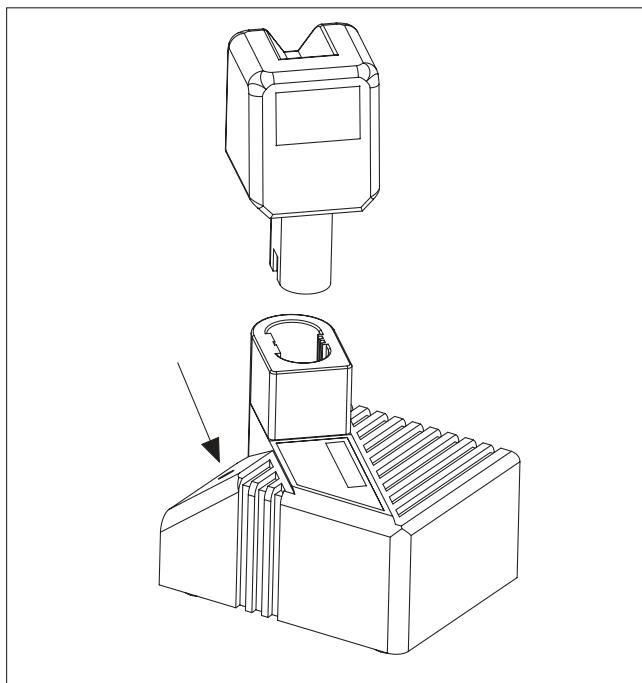

Fig. 2

Continuous light 

Ready for charging
Battery not inserted:
Main voltage is on.

Flashing light 

Rapid charging
Rapid charging operates until the battery is fully recharged. The battery charger automatically switches to trickle- and trickle charging.

Continuous light 

Trickle charging
Battery inserted: The battery charger is only delivering a trickle charge because the battery is already fully charged.

Double flashing 

Temperature Warning: The battery is too hot (or too cold). Trickle charging only. The battery charger automatically switches to rapid charging when the temperature is in the permitted range again.

Quick flashing 

Error message Warning: Battery can not be charged (battery defective or battery charger slot dirty).

 For detailed information, refer to operating instructions for the battery charger.

5

INITIAL OPERATION

5.1 BATTERY CHARGER

230 V (115 V) battery chargers can be operated at 220 V or 240 V (110 V).

The battery charger is suitable only for charging (NiCd/NiMH) batteries (voltage between 7.2 V and 11.4 V) from the Bosch range of tools.

AL 30 DV 1450
7.2 V - 14.4 V • 5.0 A

Fig. 3

5.2 FIRST BATTERY CHARGE



Please note the following points in order to obtain optimum battery life:

- Connect battery charger (4/3) to mains voltage.
- Insert adapter (4/2) into battery charger slot.
- Insert battery (4/1) into battery charger.

For the first charge, leave the battery in the charger for at least five hours, regardless of the battery indicator. (The charging time for all subsequent charges is about 14 minutes)

For all subsequent charges, only recharge the battery when the red indicator light on the OR-T tool comes on (see section 7.1). Avoid constant charging when the battery is not yet discharged. This will ensure optimum battery capacity and life.

Maximum battery output will be reached after four or five charging/discharging cycles.

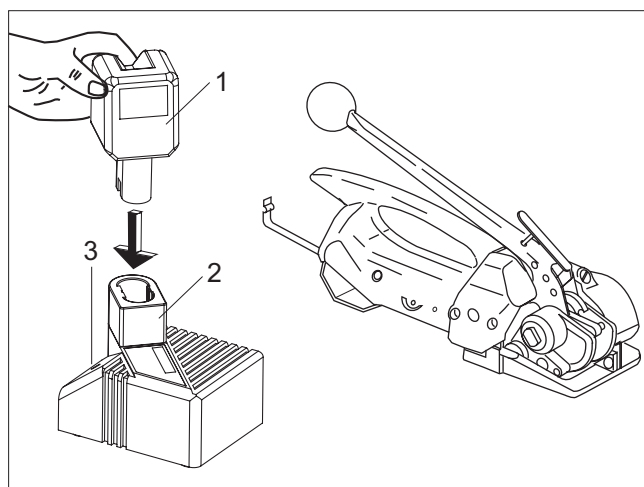

Fig. 4

5.3 CHARGING THE BATTERY

The charging process and error functions are indicated by a green light (4/3), see chapter 4.2.

The charging time is approx. 14 min.

The maximum charging current flows when the temperature of the battery is between 15–45°C. Avoid charging at battery temperatures below 0°C.



If the battery is not to be used for a longer period (several days), it should be removed from the tool and charged in the battery charger.

The intelligent charger with fuzzy control charges the battery with the optimum rapid charging current, depending on temperature and capacity. If fully charged, a preserving charge will prevent self-discharge and thus guarantee a long battery life.

6

OPERATING INSTRUCTIONS

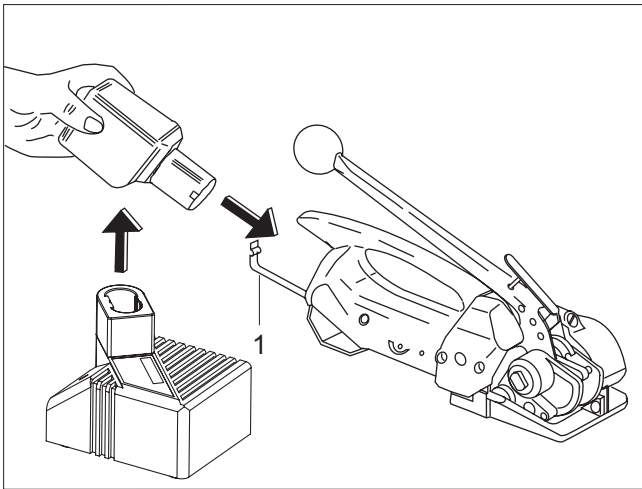

Fig. 5

6.1 OPERATING THE TOOL

- Insert charged battery and close the bow spring (5/1).

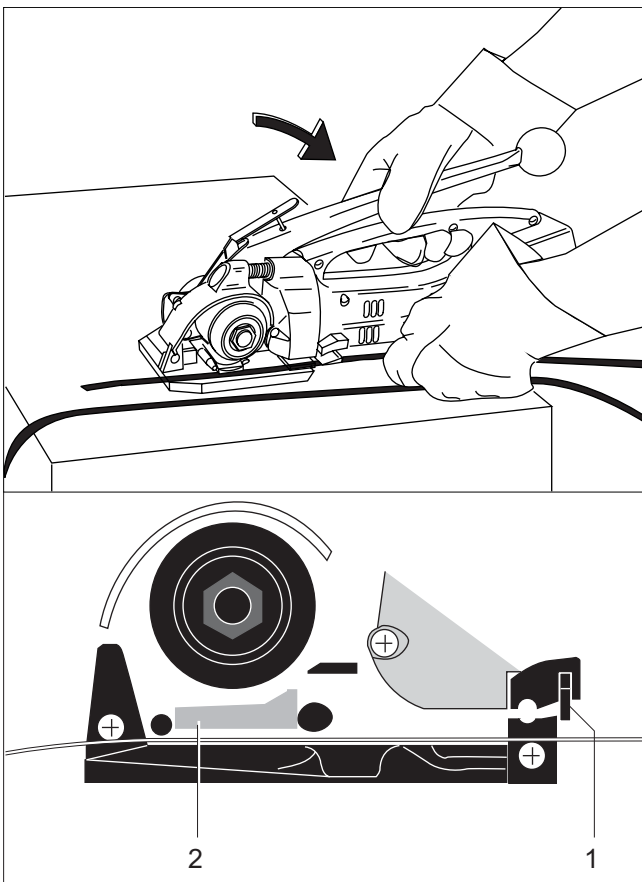

Fig. 6

- Place the strap around the package and hold it with the left hand so that the lower strap lead is approx. 20 cm (8") away from the hand.
- Take the tool with the right hand and press the lever towards the handle.
- Slide the strap lead under the tension shoe (6/2) and under the cutting device (6/1) into the tool until the stop is reached.



The lower strap is now approx. 5 cm (2") beyond the tool.

- Release the lever.

- Insert the strap from coil holder between the tension wheel (7/3) and the tension shoe (7/2). Then insert the strap into the slot of the cutting device (7/1) until stop is reached.

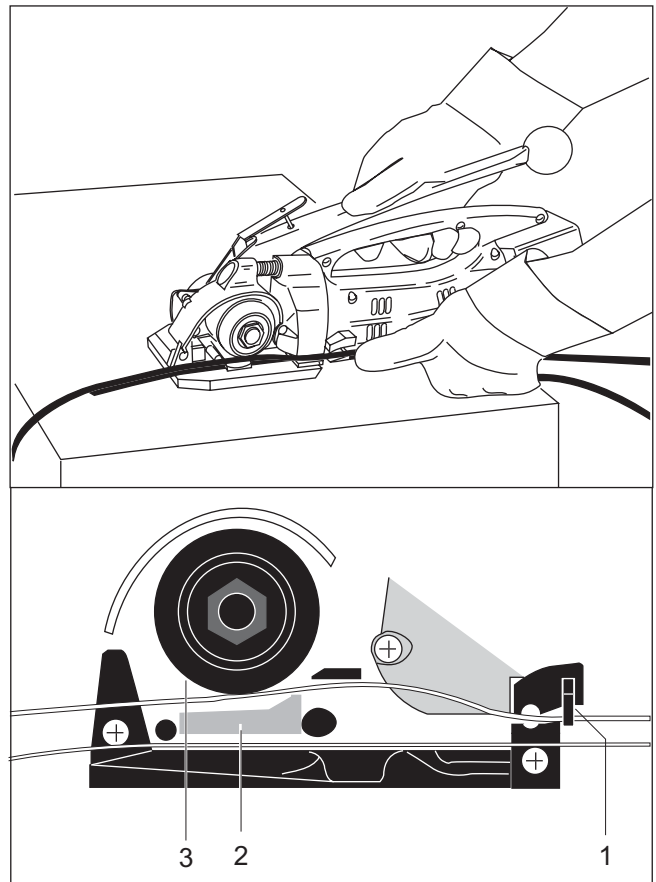

Fig. 7

- Hold the tool by the grip with the left hand and move the tension lever with the right hand back-and-forward until the desired strap tension is reached.



The maximal strap tension is adjustable (see chapter 7.3).

If the tool is used in a dusty environment, it is recommended to clean the tool regularly. The tension wheel in particular should be kept clean (see chapter 7.5).

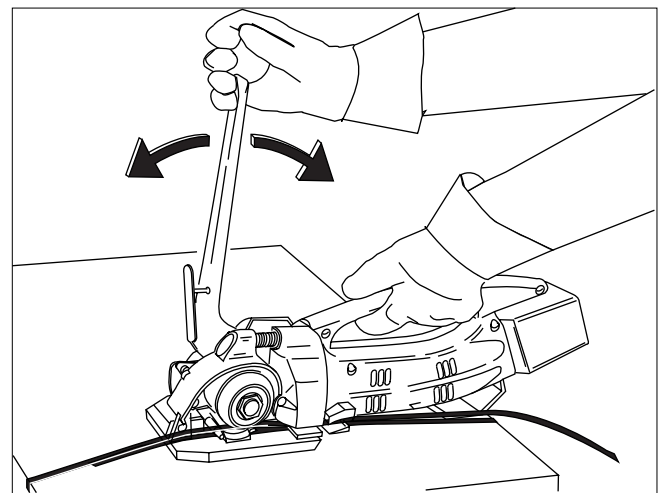

Fig. 8

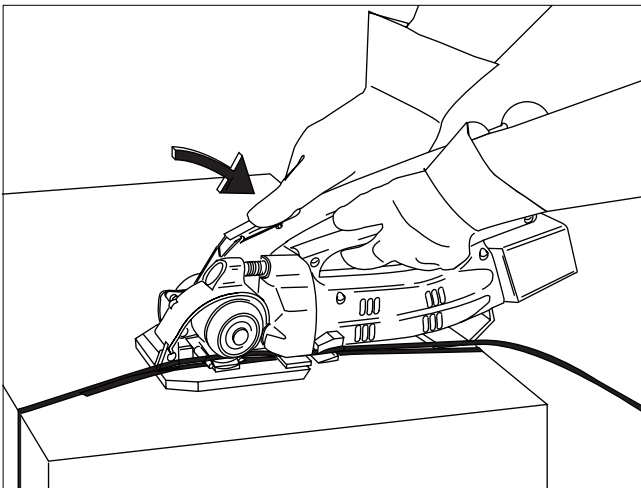

Fig. 9

- Bring back the tension lever to the intermediate position, push the yellow welding lever towards the tension lever. Now the tool is ready for sealing the straps.

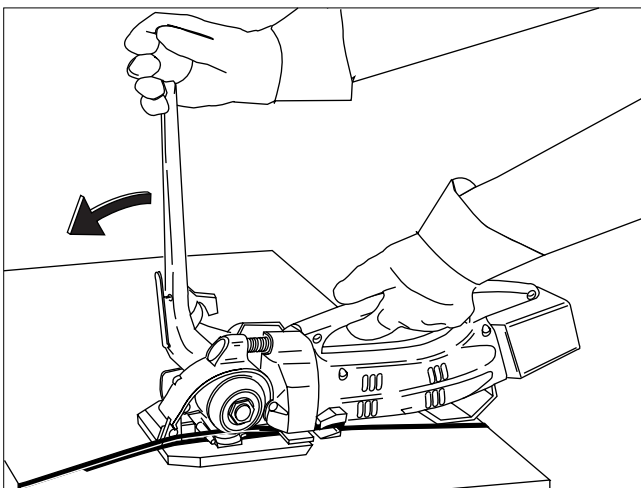





Fig. 10

- Push lever to stop (sealing position). The left hand remains on the handle of the tool to bear the counterforce.

 The straps are welded together and the upper strap is cut off. The signal lamp (12/1) indicates the following functions:

Flashing green light  After finishing the friction welding, the green light flashes for approx. two sec. The sealing lever must stay in the sealing position, during this time.

Continuous green light  When the green light is on continuously, the sealing cycle is finished.

Continuous red light  When the red light is on continuously, the battery must be charged (see chapter 5.2).

 When the red signal lamp lights up, the unit is blocked, since the remaining charge in the battery is insufficient to ensure proper welding of the straps.

- Press lever against the handle. Then swing the tool away from the strapping to the right at the rear.

 If the straps are poorly welded, check the setting of the welding time (see chapter 7.2).

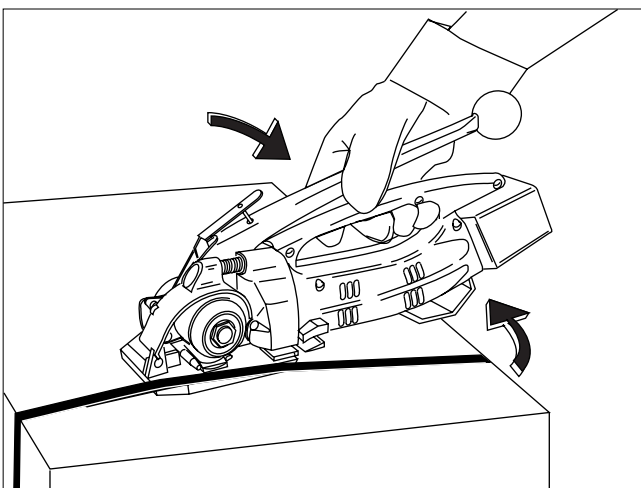

Fig. 11

7

PREVENTIVE AND CORRECTIVE MAINTENANCE

7.1 CHANGING THE BATTERY

Continuous red light



If the red signal lamp (12/1) is lit continuously, the battery must be charged (see chapter 5.2).

- Open bow spring and remove discharged battery.
- Insert charged battery and lock with bow spring.



When changing the battery, the new battery must only be inserted after approx. five seconds to ensure that the electronic system can reset to the initial position. If the battery change is too rapid, the red signal lamp lights up and the unit remains blocked.

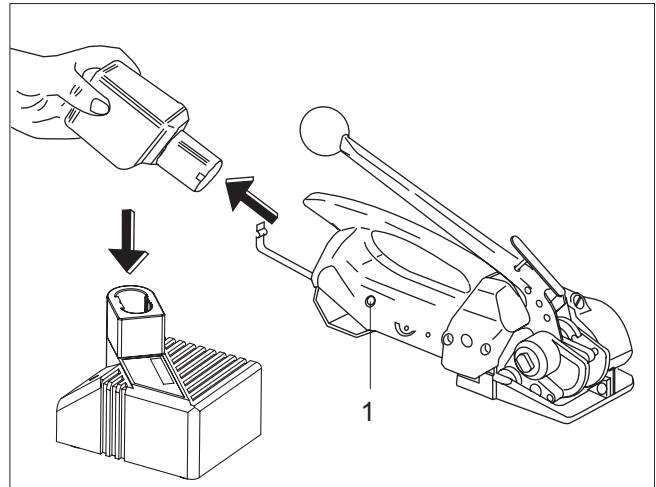

Fig. 12

7.2 ADJUSTING WELDING TIME

- The welding time can be infinitely adjusted with a screwdriver (no 1), depending on strap quality and dimension.
- By turning the screw carefully clockwise, the welding time will be longer, by turning counterclockwise it will be shorter.



The printed circuit board could be damaged if the screw is turned too far either clockwise or anticlockwise.

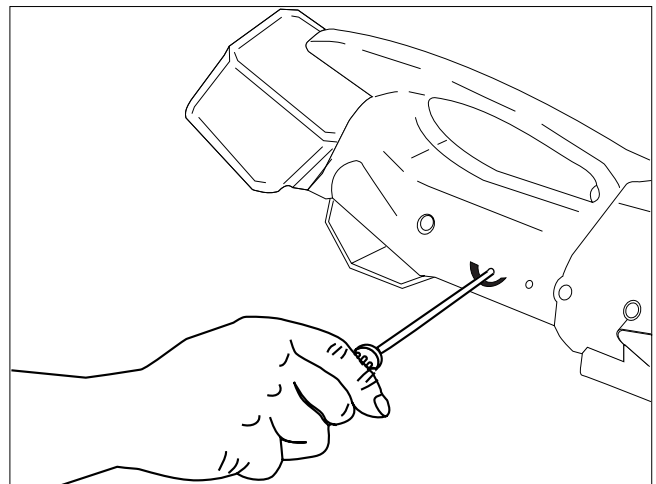

Fig. 13



If straps are poorly welded, there is the risk that the seal will tear. We advise you to regularly check the strap seals.

- 1 Poorly welded seal (not welded over the complete surface), welding time too short.
- 2 **Good seal** (the complete surface is cleanly welded without excess material being forced out sideways).
- 3 Poorly welded seal (excess material is forced out sideways), welding time too long.



The welding time for PET straps is longer than for PP straps.

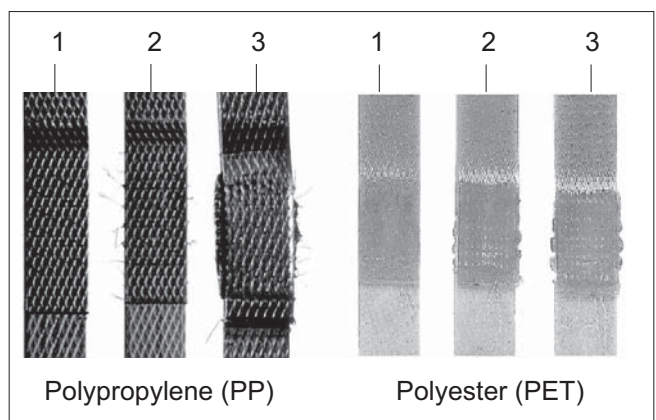

Fig. 14

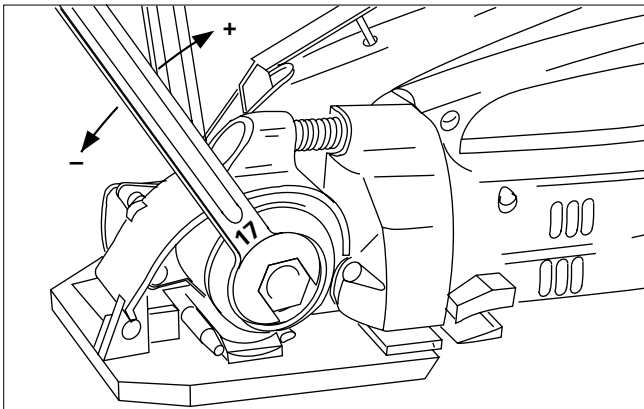

Fig. 15

7.3 ADJUSTING STRAP TENSION

The maximum strap tension is determined by the adjustment of the friction clutch. For this reason two fork wrenches are supplied.

- Block the tension shaft with the small fork wrench (SW 11).
- With the other fork wrench (SW 17) adjust the nut.
- Turning the nut in clockwise direction the strap tension is increased.
- Turning the nut in counterclockwise direction the strap tension is reduced.

Best results are achieved by adjusting the clutch to the maximum tension for the package being strapped. But not as tight that the tension wheel will turn over or the strap breaks.

7.4 ADJUSTING STRAP WIDTH

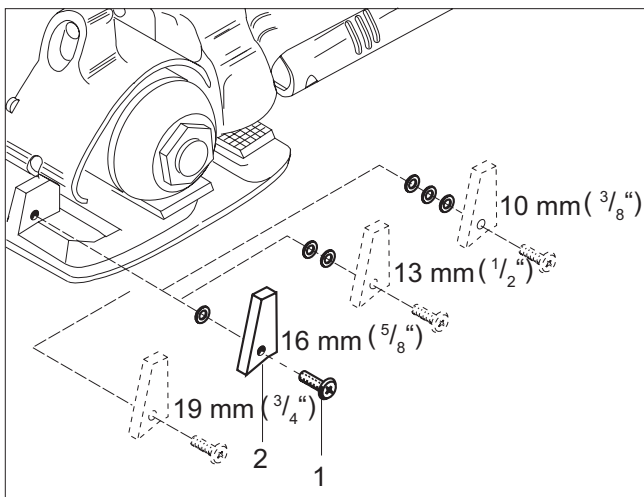

Fig. 16

- To change the strap width, the strap stop (16/2) must be removed with the screw (16/1) from the tool and refitted with washers (1.5 mm thick) according to the width of the strap.
- Strap width 19 mm ($\frac{3}{4}$ ") without washer
- Strap width 15–16 mm ($\frac{5}{8}$ ") one washer
- Strap width 12–13 mm ($\frac{1}{2}$ ") two washers
- Strap width 9–10 mm ($\frac{3}{8}$ ") three washers

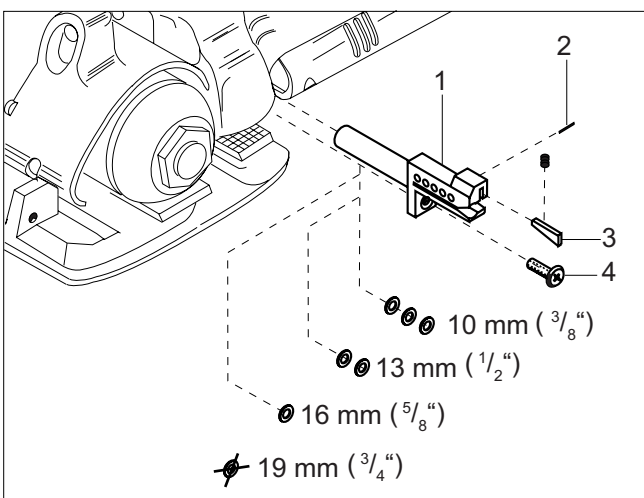



Fig. 17

- Loosen screw (17/4) and remove knife bushing (17/1).
- Withdraw rollpin (17/2) and move the pawl (17/3) to desired position according to strap width. Replace rollpin (17/2).
- Insert washers between base plate and knife bushing according to strap width.
- Tighten screw (17/4).
- Strap width 19 mm ($\frac{3}{4}$ ") without washer
- Strap width 15–16 mm ($\frac{5}{8}$ ") one washer
- Strap width 12–13 mm ($\frac{1}{2}$ ") two washers
- Strap width 9–10 mm ($\frac{3}{8}$ ") three washers

7.5 CLEANING THE TOOL

 If the tool is used in a dusty environment, it is recommended to clean the tool regularly. The tension wheel (18/1) in particular should be kept clean.

- Clean the tension wheel with the steel brush supplied with the tool.
- If the tension wheel tooting is covered with heavy dirt, it must be carefully cleaned with a screwdriver or a marking tool.

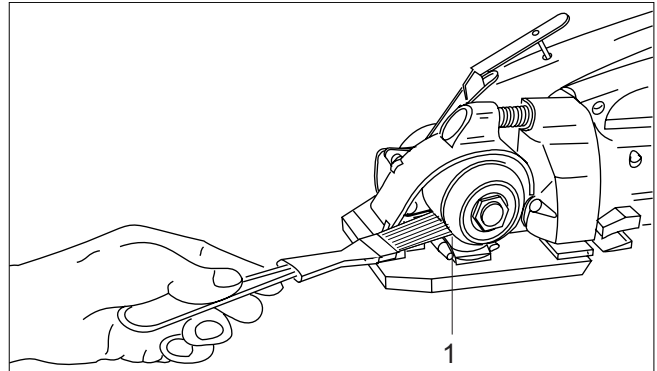

Fig. 18

7.6 CHANGING THE TENSION WHEEL

Removal

- Open bow spring (19/2) and remove battery (19/1).
- Block the tension shaft (19/9) with the small fork wrench (SW 11).
- With the other fork wrench (SW 17) loosen the nut.
- Remove five spring washers (19/4) and carrier (19/3).
- Press tension lever and remove pin (19/10).
- Remove tension wheel (19/7) together with the clutch disks (19/6) and (19/8).
- Check clutch disks for wear, if necessary replace it. Replace tension wheel.

Installation

- Install the parts in reverse order.

 Do not lubricate the clutch disks. Adjust the maximum tension force (see chapter 7.3).

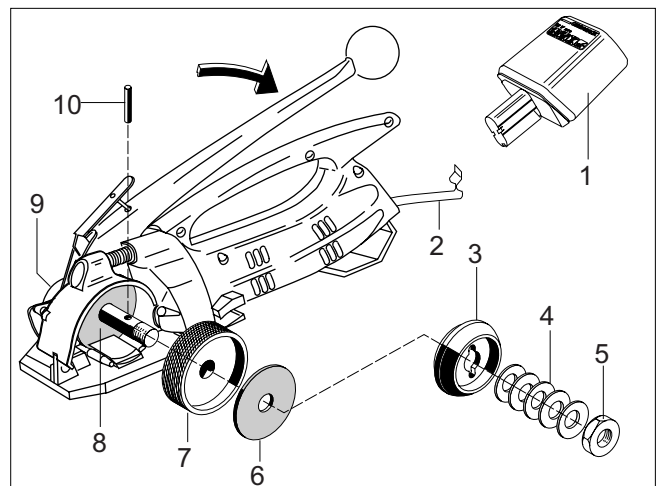

Fig. 19

7.7 CHANGING THE TENSION SHOE

Removal

- Open bow spring (20/2) and remove battery (20/1).
- Push the tension lever forward until the stop is reached.
- Remove set screw (20/5) with compression spring (20/6) and bolt (20/7).
- Release set screw (20/9).
- Push out shaft (20/8) with a small screwdriver.
- Raise rocker unit (20/10) and remove and replace tension shoe (20/3).
- Clean tooth plates and tension wheel.

Installation

- Install the parts in reverse order.

 Before inserting the rocker unit (20/10) lift stroke lever (20/4) that the switch link of the rocker lies below the stroke lever. After mounting the shaft turn the tension wheel until the rocker moves down. Screw in set screw (20/9) until it is in line with the casing.

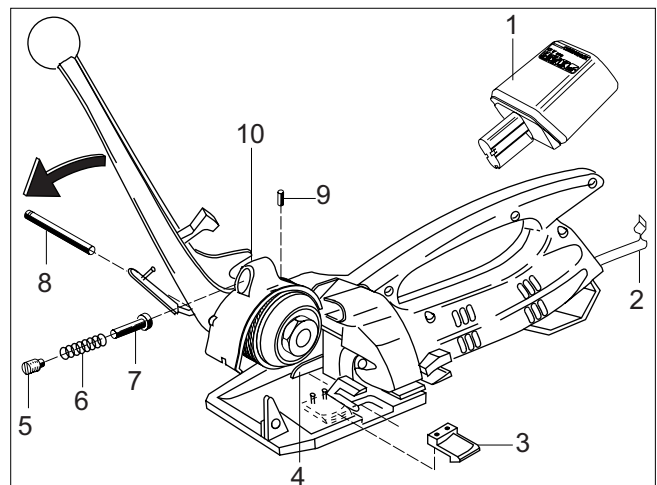

Fig. 20